



MBC-IQ-LAB
IQ Modulator Bias Controller

ELECTRONICS



The MBC-IQ-LAB is a bias controller designed to stabilize the three operating bias points of a dual parallel modulator. This new version is fully automated and uses a reduced dither signal to provide a rock stable setpoint of your phase delays over time and environmental conditions. It has been designed for optimal performance in CS-SSB applications to ensure a robust and steady optical carrier extinction.

Finally, a user-friendly Graphical User Interface - GUI - is provided for monitoring and (manual) setpoint adjustments if desired.

FEATURES

- Designed for I&Q modulators
- Automated bias points (Min, Min, Quad)
- High stability
- High sensitivity

APPLICATIONS

- Analog communications CS-SSB

OPTIONS

- Internal photodiode and tap coupler
- Dual drive IQ modulator

Performance Highlights

Parameter	Min	Typ	Max	Unit
DC bias voltage	-12	-	+12	V
Automated locking points	DC1 MIN, DC2 MIN, DC3 QUAD±			-
Control	Remote			-



Bias Control Characteristics

Parameter	Symbol	Condition	Min	Typ	Max	Unit
Timing						
Autoset	Auto	Automatic scan	-	20	-	s
Initialisation	-	Bias control stabilization time after a scan	-	30	180	s
Efficiency						
Optical output power stability	-	Standard deviation, over 2 hours, and modulator temperature controlled	-	± 0.1	-	dB

Electrical Characteristics

Parameter	Symbol	Condition	Min	Typ	Max	Unit
DC1, 2 bias voltage	V_{bias}	VDC_1, VDC_2	-12	-	+12	V
DC3 bias voltage	V_{bias}	VDC_3	-13.5	-	+13.5	V
Locking point	DC_1	Automated	MIN (0 %)		-	-
	DC_2	Automated	MIN (0 %)		-	-
	DC_3	Automated	QUAD- (-50 %), QUAD+ (+50 %)		-	-
Dither frequency DC_1	F_{DC1}	-	-	1120	-	Hz
Dither frequency DC_2	F_{DC1}	-	-	840	-	Hz
Dither amplitude	$V_{DC1, 2, 3}$	-	5	-	1 000	mVpp
Dither amplitude step	$\Delta V_{DC1, 2, 3}$	-	1	-	-	mVpp

Optical Characteristics

Parameter	Symbol	Condition	Min	Typ	Max	Unit
MBC-IQ-LAB-A1: MBC with embedded PD and tap-coupler						
Wavelength	λ	-	1530	1550	1625	nm
Insertion loss	IL	-	-	1.4	-	dB
MBC-IQ-LAB-A0: MBC without PD and tap-coupler						
Wavelength	λ	MBC-IQ-LAB-A0	900	-	1 600	nm

MBC-IQ-LAB-A0: set-up with an IQ modulator

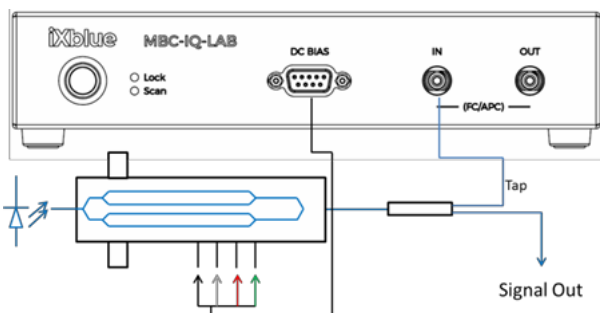

MBC-IQ-LAB-A1: set-up with an IQ modulator

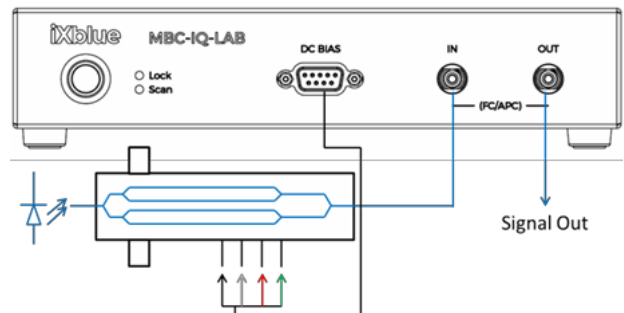



MBC-IQ-LAB
IQ Modulator Bias Controller

ELECTRONICS

Absolute Maximum Rating

Stresses in excess of the absolute maximum ratings can cause permanent damage to the device. These are absolute stress ratings only. Functional operation of the device is not implied at these or any other conditions in excess of those given in the operational sections of the data sheet. Exposure to absolute maximum ratings for extended periods can adversely affect device reliability.

Parameter	Symbol	Condition	Min	Typ	Max	Unit
Operating temperature	-	-	-10	-	+45	°C
Storage temperature	-	-	-40	-	+70	°C

Output Power Stability

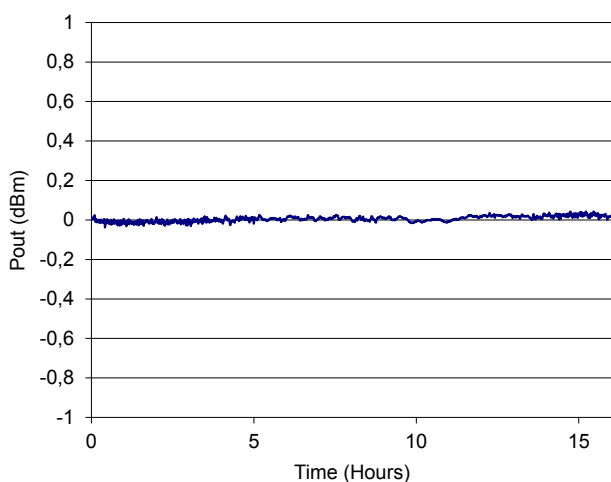

Graphical User Interface

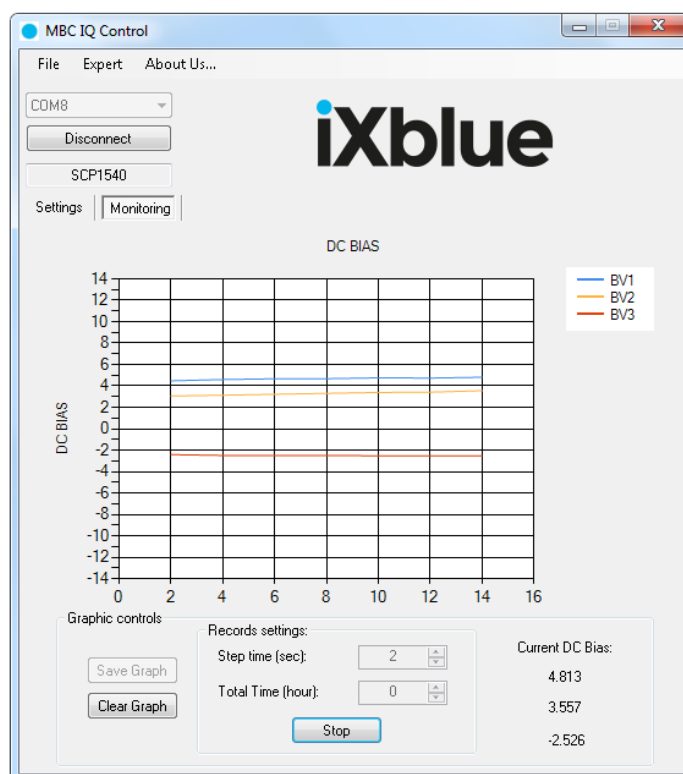



MBC-IQ-LAB
IQ Modulator Bias Controller

ELECTRONICS

MBC-IQ-LAB

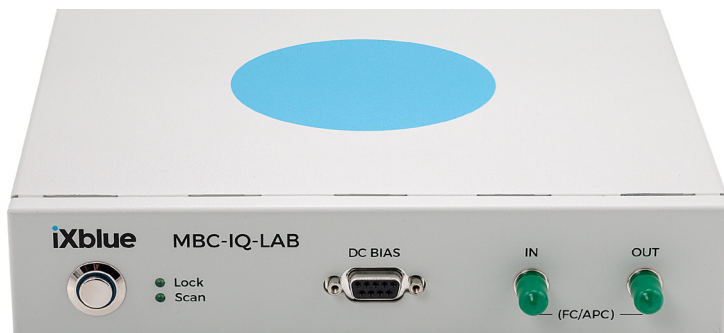

Dimensions	
Dimensions (W x H x D)	220 mm x 220 mm x 52 mm
Power supply (rear panel)	100-120 V / 220-240 V automatic switch, 50-60 Hz
Interfaces	
Photodiode Input /coupler input	FC/APC connector
Bias Output	Specific DB9 connector to single channel connector
Communication	USB
Remote Control	
Minimum computer requirements	Windows XP SP3
Computer configuration	Recommended Windows XP-SP3, W7, W8

Ordering information

MBC-IQ-LAB-A0: No coupler, 900nm to 1600nm
MBC-IQ-LAB-A1: Integrated coupler ,1530 nm to 1625 nm

About us

iXBlue Photonics produces specialty optical fibers and Bragg gratings based fiber optics components and provides optical modulation solutions based on the company lithium niobate (LiNbO₃) modulators and RF electronic modules. iXBlue Photonics serves a wide range of industries: sensing and instruments, defense, telecommunications, space and fiber lasers as well as research laboratories all over the world.

3, rue Sophie Germain
25 000 Besancon - FRANCE

iXblue reserves the right to change, at any time and without notice, the specifications, design, function or form of its products described herein. All statements, specification, technical information related to the products herein are given in good faith and based upon information believed to be reliable and accurate

